



Haze Battery Company Ltd



**Sealed Lead Acid 2 Volt Bloc
Gelled Electrolyte Range**

CONSTRUCTION - Gel battery construction is as shown in the diagram. The positive and negative grids are cast from a calcium/tin lead alloy to reduce grid growth and corrosion. The active material is manufactured from a high purity lead (99.9999%) to minimize the negative effects of impurities.

Separator is manufactured by a world leader in the field, utilizing the latest German technology. The base material is a microporous duroplastic exhibiting excellent high temperature stability and mechanical strength, resulting in very good resistance to vibration and mechanical shock. The integrity of the battery will be maintained under extreme conditions.

The purpose of the separator is to maintain a constant distance between the positive and negative plates, totally eliminating the possibility of short circuits whilst allowing the active materials to fully react with the gelled electrolyte.

The separator also has an open construction, which allows little resistance to the flow of the electrolyte during filling.

A thin layer (typically 0.4mm) of non-woven glass mat is an integral part of the separator and is placed against the positive plate for improved surface contact.

A compression platform at the bottom of the cell allows expansion and contraction of the plates.

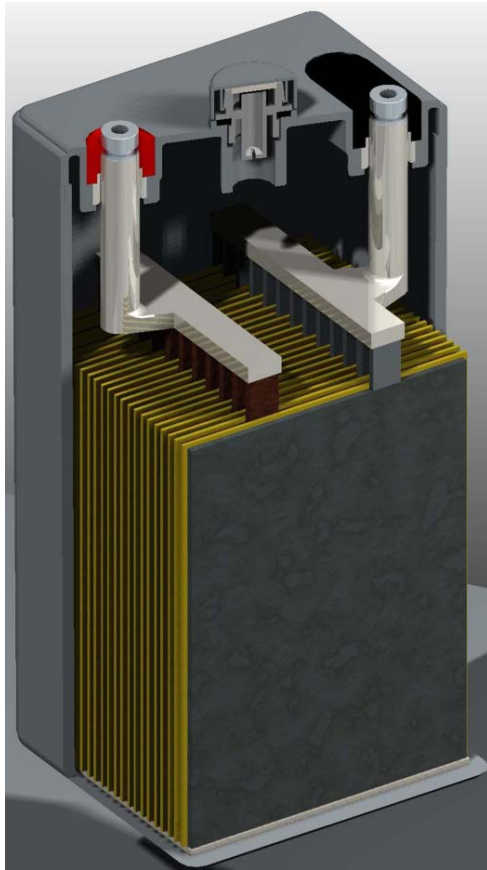

Gel construction with case removed and cover cut away to show internal battery parts.

ELECTROLYTE FILLING - Gelled electrolyte is introduced to the cell by means of custom-built vacuum filling machines. It is vitally important that the electrolyte achieves full penetration of the separator and plates; therefore, vacuum cycling is utilized after the filling process. To ensure each cell has the correct amount of gel, they are first overfilled, the extra gel is then removed. The battery design and construction negates the need for electrolyte addition and the battery remains maintenance free throughout its design life.

SAFETY RELEASE VALVE- The battery will operate above atmospheric pressure under normal operating conditions, however the maximum pressure is governed by the safety release valve. Open is activated by pressures in excess of approx. 2 psi (14 Kpa), resealing at approx 1.2 psi (8.4 Kpa).

Flame Arrester - All models above and including HZB2-150 have a built in flame arrester in the valve assembly.

GAS RECOMBINATION - The gasses generated during normal operation of the battery are internally recombined. In fact more than 99% of the gas achieves recombination.

TERMINAL CONSTRUCTION - The contact quality between the insert terminal and the lead post is of vital importance during short duration / high Amp discharges. Elevated terminal temperatures are the result of poor contact, eventually causing seal degradation and electrolyte leaks. Haze design and assembly technique for terminal casting ensures trouble free operation for the design life of the battery.

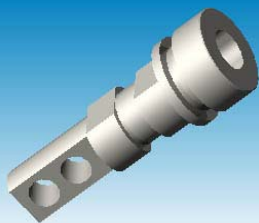

Gel Vs AGM

Each battery has its advantages and disadvantages, it is therefore important to choose the right battery for the application. Advantages of Gel Batteries:

- Full recovery from deep discharge, even when the battery is not recharged immediately.
- Ideal for repeat cycling daily use.
- Excellent performance over long discharges
- Good tolerance to higher temperature applications
- Suitable where mains power is unstable
- Zero stratification due to immobilized electrolyte
- No equalization charge necessary
- Reduced self-discharge
- Limiting design protects the positive plates to greatly improve cycle life
- Thicker plates for reduced grid corrosion and increased cycle life
- Improved charge acceptance due to low internal resistance
- High resistance to water loss with the right charging set up
- Ultra stable polymer separator with glass mat for increased performance
- High resistance to shorting due to superior mechanical strength of the polymer separator
- Increased tolerance to poor charging parameters
- Can be discharged even when full recharge has not been achieved, without loss of battery capacity



Applications

- Cycling / Float service
 - Residential
 - Telecommunications
 - Refrigeration
 - Photovoltaic
 - Solar
 - Wind
 - Engine Starting
 - Electric Vehicle
 - Water Pumping
 - Cathodic Protection
 - Boats
 - General Marine
 - Navigation Aids
- Many other deep cycle applications

Capacity temperature correction Factor to be applied to Data at 20 Degrees C

Discharge Time	-30 °C	-20 °C	-10 °C	0 °C	5 °C	10 °C	15 °C	20 °C	25 °C	30 °C	35 °C	40 °C	50 °C
5 minutes to 59 minutes	0.23	0.417	0.605	0.778	0.86	0.91	0.96	1	1.037	1.063	1.085	1.1	1.116
1 Hour to 100 Hours	0.277	0.464	0.647	0.816	0.886	0.93	0.97	1	1.028	1.05	1.063	1.07	1.078

CHEMICAL REACTION- The chemical reaction for the Discharge / Recharge process is represented by the following formula:

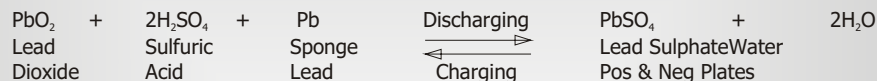

Under normal float charge conditions the oxygen passes through the separator from the positive to the negative plate where it reacts with the negative active material to form lead oxide.

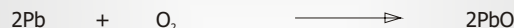

In the acid conditions the lead oxide reacts with the sulfuric acid to form lead sulphate.

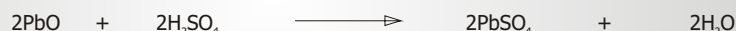

The lead sulphate formed on the negative is then reduced to lead and sulfuric acid by the evolving hydrogen.

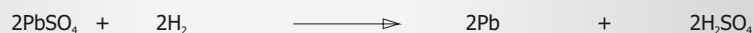

If the equations are resolved and like terms cancelled out on both sides of the equation the result is:

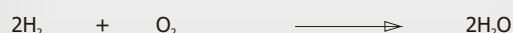

This reaction summarises what is meant by GAS RECOMBINATION. The process can never be 100% efficient, normal recombination efficiency is 95 - 99%.

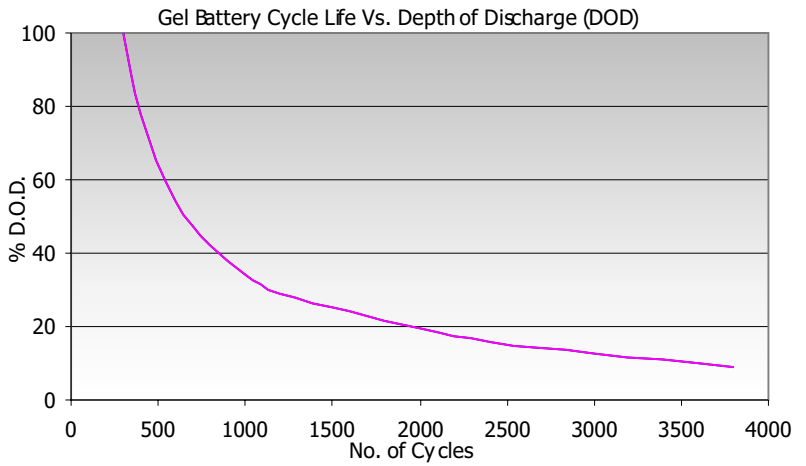

Innovative Features

- Completely maintenance free, sealed
- Construction eliminates the need for watering
- Electrolyte will not stratify, no equalization charge required
- Increased durability and deep cycle ability for heavy demand applications
- Special formation process
- Gelled thixotropic electrolyte
- Spill proof / leak proof
- Valve regulated Max internal pressure 2.5 psi
- Multi-position usage
- Multi-cell container
- ABS Case and cover - VO on request
- Low self discharge
- Utilising the latest in German technology
- FAA and IATA approved as non-hazardous
- Built to comply with IEC 896-2, DIN 43534, BS 6290 Pt4, Eurobat.

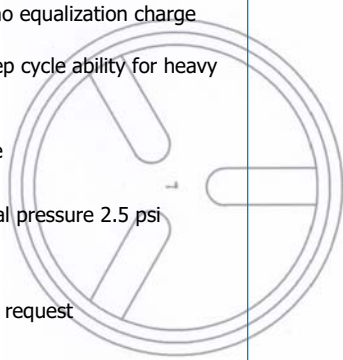

Specifications

Nominal Voltage	2 Volts
Design Life	15 Years
Operating Temperature	-20 °C to 50 °C
Grid alloy	Calcium / Tin lead alloy
Plates	Flat Pasted
Separator	Microporous Duroplastic
Active material	Very high purity lead
Case and cover	ABS (VO on request)
Charge Voltage	Float - See table, Cycling 2.4 @20 °C
	Max. 2.4 VPC Max ripple 3.5
	Charging V
Electrolyte	Sulphuric acid Analytical grade purity
Venting Valve	EPDM Rubber 1.5 to 2 psi (10.5 - 14 KPa) release pressure. Resealing at 1 psi (7 KPa)
Terminal	Various types Epoxy sealed by extended mechanical paths
Torque setting	The recommended torque value for all types is 5-7 Nm
Cables	Insulated cables / connectors supplied on request.

Haze Battery Company keenly encourages environmental awareness; PLEASE follow guidelines for the recycling /disposal of lead.

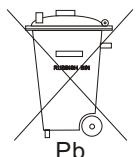
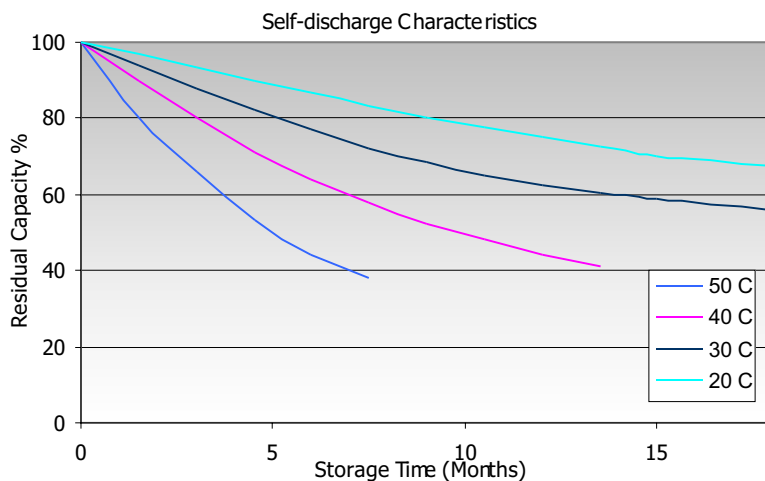

Relationship Between Charge Voltage and Temperature

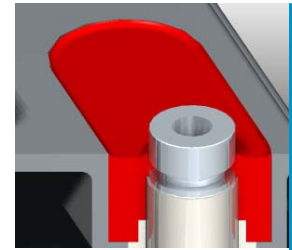
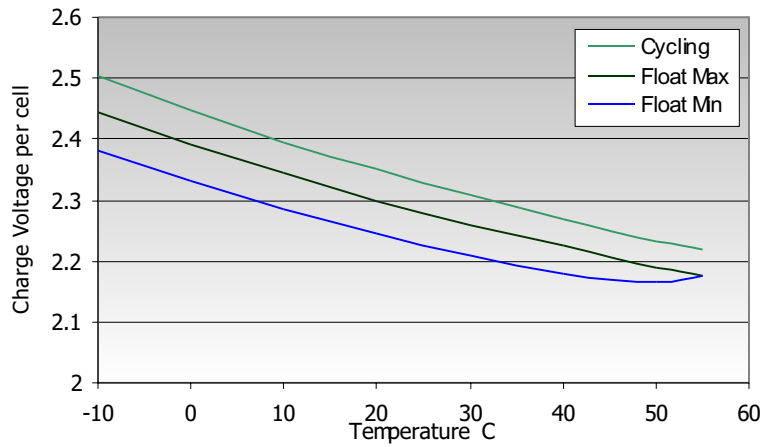

Capacity Vs Ambient Temperature

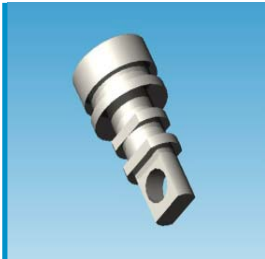
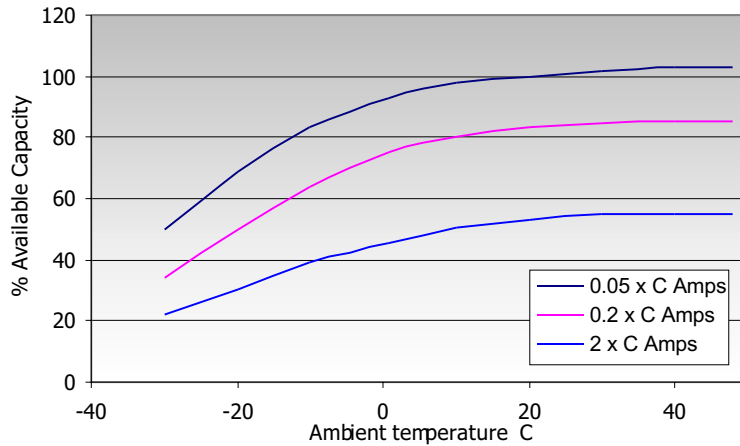

CHARGING CHARACTERISTICS

Floating - The optimum float voltage for a battery is temperature dependant, at 15 - 24°C the recommended value is 2.27 - 2.30V. It is recommended that battery installation sites are temperature controlled, however float voltage can be increased or decreased to compensate for temperature variations. Adjustment is calculated at +/- 3 mV per degree C.

Operating Temperature	Recommended Applied Float Voltage VPC
0-9	2.33 - 2.35
10-14	2.30 - 2.33
15-19	2.27 - 2.30
20-24	2.27 - 2.30
25-29	2.25 - 2.27
30-34	2.23 - 2.25
35-40	2.21 - 2.23

The most suitable charging method for battery life and performance is the constant voltage method with a limited initial current, usually limited to a maximum of $C_{20}/4$.

HAZE Amps & Ampere Hour Data

Battery Model	Time in Minutes - Amps to 1.85 VPC						
	15	20	25	30	45	60	90
HZY2-50	65.6	57.3	51.1	45.4	34.4	27.8	20.1
HZY2-100	137	117	103	92.8	70.5	56.9	41.2
HZY2-150	193	166	146	130	98.8	80.8	59.6
HZY2-200	209	189	175	161	129	108	80.5
HZY2-250	254	236	218	202	162	135	100
HZY2-300	301	276	254	236	193	161	121
HZY2-375	380	347	319	296	240	199	149
HZY2-400	411	374	347	320	258	216	162
HZY2-450	470	428	392	360	290	243	181
HZY2-500	522	478	441	407	323	267	201
HZY2-575	572	532	495	460	368	302	228
HZY2-600	603	559	518	482	387	323	241
HZY2-625	644	584	542	503	403	337	251
HZY2-750	748	702	653	606	489	405	303
HZY2-800	808	748	695	646	516	427	321
HZY2-1000	1004	927	866	800	645	534	402
HZY2-1250	1280	1169	1082	996	807	669	502
HZY2-1500	1532	1406	1303	1202	968	805	607
HZY2-1875	1931	1767	1615	1488	1193	997	746
HZY2-2000	2008	1847	1703	1582	1290	1078	802
HZY2-2500	2420	2241	2083	1956	1600	1333	1011
HZY2-3000	2916	2718	2529	2348	1915	1591	1209
HZY2-3850	3760	3474	3215	2984	2432	2040	1539

Battery Model	Time in Minutes - Amps to 1.80 VPC						
	15	20	25	30	45	60	90
HZY2-50	71.1	61.6	54.5	48.3	37.0	29.8	21.6
HZY2-100	147	126	110	97.7	74.0	59.3	43.3
HZY2-150	208	178	157	140	106	85.8	63.7
HZY2-200	229	203	187	173	139	114	85.1
HZY2-250	281	255	236	217	174	143	107
HZY2-300	337	303	277	256	208	172	128
HZY2-375	418	379	343	316	255	212	159
HZY2-400	449	408	375	344	276	228	171
HZY2-450	520	472	432	393	312	257	193
HZY2-500	586	521	474	437	347	285	214
HZY2-575	639	582	532	490	396	325	244
HZY2-600	671	612	560	520	416	344	255
HZY2-625	709	642	591	545	433	357	267
HZY2-750	852	774	710	656	521	427	318
HZY2-800	898	819	754	694	555	456	340
HZY2-1000	1122	1020	941	866	694	569	427
HZY2-1250	1408	1272	1169	1068	859	710	530
HZY2-1500	1684	1533	1408	1294	1041	857	642
HZY2-1875	2116	1902	1757	1606	1283	1058	789
HZY2-2000	2245	2016	1831	1702	1379	1145	848
HZY2-2500	2806	2529	2316	2142	1734	1423	1067
HZY2-3000	3367	3024	2779	2562	2053	1699	1278
HZY2-3850	4308	3886	3550	3290	2651	2181	1643

Battery Model	Time in Minutes - Amps to 1.75 VPC						
	15	20	25	30	45	60	90
HZY2-50	74.4	64.4	56.7	50.6	38.4	30.8	22.2
HZY2-100	154	131	114	103	77.6	62.0	44.9
HZY2-150	220	188	166	147	112	91.0	67.0
HZY2-200	248	219	200	184	148	121	89.6
HZY2-250	304	276	251	230	184	151	112
HZY2-300	367	325	295	269	216	179	133
HZY2-375	452	404	367	335	270	223	166
HZY2-400	492	442	399	364	291	239	179
HZY2-450	560	501	454	412	328	272	201
HZY2-500	627	559	502	458	364	301	223
HZY2-575	692	618	566	522	419	342	253
HZY2-600	718	652	597	549	439	361	269
HZY2-625	763	683	622	566	448	371	277
HZY2-750	916	822	751	690	552	452	336
HZY2-800	968	870	797	734	584	482	357
HZY2-1000	1228	1098	1002	918	729	600	446
HZY2-1250	1508	1347	1224	1122	903	745	554
HZY2-1500	1792	1620	1488	1362	1087	893	668
HZY2-1875	2268	2046	1858	1696	1359	1118	837
HZY2-2000	2404	2157	1968	1806	1448	1200	888
HZY2-2500	3048	2730	2479	2270	1817	1494	1112
HZY2-3000	3624	3249	2959	2712	2179	1795	1344
HZY2-3850	4560	4098	3718	3430	2757	2277	1707

Battery Model	Time in Hours								Amps to 1.85 VPC					
	2	3	4	5	6	8	10	12	24	48	72	100	120	
HZY2-50	16.2	12.0	9.70	8.20	7.12	5.69	4.70	4.00	2.18	1.16	0.79	0.58	0.48	
HZY2-100	32.8	24.2	19.5	16.4	14.3	11.4	9.40	7.99	4.30	2.28	1.57	1.16	0.98	
HZY2-150	48.6	36.2	29.2	24.7	21.4	17.2	14.1	12.0	6.45	3.38	2.32	1.71	1.44	
HZY2-200	65.3	48.0	38.8	32.9	28.6	22.8	18.9	16.1	8.67	4.58	3.15	2.32	1.94	
HZY2-250	81.6	60.5	48.9	41.1	35.8	28.4	23.6	20.1	10.8	5.73	3.92	2.89	2.43	
HZY2-300	97.9	72.5	58.4	49.3	42.9	34.1	28.3	24.1	12.9	6.83	4.71	3.46	2.90	
HZY2-375	122	90.0	72.9	61.8	53.7	42.5	35.3	30.1	16.1	8.60	5.96	4.35	3.64	
HZY2-400	131	96.5	77.8	65.8	57.0	45.0	37.5	32.0	17.1	9.15	6.32	4.64	3.89	
HZY2-450	147	109	87.0	73.7	64.2	51.0	42.2	36.0	19.2	10.2	7.01	5.19	4.35	
HZY2-500	163	122	97.8	82.4	71.5	56.9	47.2	40.1	21.4	11.3	7.81	5.80	4.87	
HZY2-575	186	137	110	93.3	81.5	64.8	53.8	45.7	24.5	12.9	8.85	6.55	5.52	
HZY2-600	196	146	117	98.6	85.6	67.6	56.3	48.1	26.0	13.7	9.36	6.85	5.74	
HZY2-625	204	150	121	102	88.9	70.9	59.0	50.2	27.0	14.1	9.68	7.15	6.01	
HZY2-750	245	182	146	124	107	85.5	70.7	60.1	32.1	17.0	11.8	8.69	7.29	
HZY2-800	261	194	157	133	115	91.9	75.5	64.2	34.4	18.2	12.6	9.27	7.78	
HZY2-1000	325	240	194	164	143	114	94.3	80.2	43.2	22.6	15.5	11.4	9.50	
HZY2-1250	407	303	245	207	180	143	118	100	53.6	28.3	19.4	14.3	12.0	
HZY2-1500	489	362	293	247	214	171	140	120	64.4	33.9	23.3	17.1	14.4	
HZY2-1875	612	453	364	308	268	213	177	150	80.6	42.4	29.1	21.3	17.8	
HZY2-2000	652	482	390	330	288	229	189	161	86.8	46.2	31.6	23.1	19.4	
HZY2-2500	815	602	486	410	356	285	236	201	108	56.5	38.3	28.0	23.5	
HZY2-3000	978	721	583	493	429	341	283	241	130	67.8	46.1	33.8	28.4	
HZY2-3850	1256	931	751	633	550	439	363	309	165	87.0	59.3	43.2	36.3	

Battery Model	Time in Hours								Amps to 1.80 VPC					
	2	3	4	5	6	8	10	12	24	48	72	100	120	
HZY2-50	17.3	12.8	10.29	8.73	7.58	6.01	5.00	4.26	2.29	1.21	0.83	0.61	0.51	
HZY2-100	34.5	25.7	20.7	17.4	15.2	12.0	9.9	8.48	4.57	2.43	1.67	1.23	1.04	
HZY2-150	51.9	38.2	30.9	26.2	22.8	18.1	15.0	12.8	6.83	3.59	2.47	1.83	1.54	
HZY2-200	69.4	51.2	41.3	35.0	30.5	24.3	20.1	17.1	9.13	4.82	3.31	2.44	2.05	
HZY2-250	86.8	64.4	51.6	43.7	37.9	30.0	24.8	21.2	11.4	6.01	4.12	3.04	2.55	
HZY2-300	104	76.9	62.0	52.1	45.2	35.8	29.7	25.2	13.5	7.15	4.94	3.66	3.07	
HZY2-375	129	96.1	77.7	65.5	56.7	44.8	37.1	31.7	16.9	9.02	6.25	4.63	3.88	
HZY2-400	139	103	82.9	70.0	60.7	48.1	40.0	34.2	18.1	9.64	6.65	4.90	4.10	
HZY2-450	156	116	93.1	78.4	68.2	53.9	44.5	37.8	20.3	10.8	7.46	5.55	4.65	
HZY2-500	174	128	103	87.5	76.1	60.6	50.2	42.7	22.7	12.0	8.30	6.16	5.18	
HZY2-575	198	146	118	100	86.8	69.0	57.2	48.6	26.0	13.7	9.46	7.00	5.89	
HZY2-600	207	154	124	105	91.1	72.0	59.6	50.9	27.4	14.4	9.86	7.25	6.08	
HZY2-625	216	160	129	108	94.0	74.9	62.2	53.1	28.5	15.0	10.3	7.66	6.42	
HZY2-750	260	193	155	131	114	90.8	75.2	63.9	34.0	18.0	12.5	9.26	7.75	
HZY2-800	277	206	166	140	122	97.4	80.3	68.3	36.3	19.3	13.4	9.88	8.28	
HZY2-1000	346	256	206	175	152	121	100	85.3	45.8	24.0	16.5	12.2	10.23	
HZY2-1250	433	321	259	219	190	151	126	106	56.5	30.1	20.7	15.2	12.8	
HZY2-1500	520	382	309	263	228	180	149	127	67.8	35.8	24.8	18.3	15.4	
HZY2-1875	650	481	387	327	285	226	188	160	85.6	45.1	31.0	22.7	19.0	
HZY2-2000	689	514	413	350	305	242	199	169	90.5	48.1	32.9	24.2	20.4	
HZY2-2500	864	642	519	439	380	303	250	213	114	60.1	40.8	29.8	25.0	
HZY2-3000	1040	771	619	525	456	363	300	255	137	71.8	49.0	35.9	30.1	
HZY2-3850	1335	994	799	673	586	463	384	327	174	92.3	62.8	45.9	38.5	

Battery Model	Time in Hours								Amps to 1.75 VPC					
	2	3	4	5	6	8	10	12	24	48	72	100	120	
HZY2-50	17.6	13.0	10.46	8.89	7.73	6.16	5.10	4.34	2.35	1.25	0.86	0.63	0.53	
HZY2-100	35.9	26.8	21.6	18.2	15.8	12.6	10.4	8.85	4.74	2.51	1.73	1.28	1.08	
HZY2-150	54.0	40.1	32.2	27.1	23.7	18.7	15.5	13.2	7.07	3.73	2.57	1.90	1.60	
HZY2-200	72.3	53.6	43.1	36.4	31.7	25.3	20.9	17.8	9.46	5.00	3.44	2.54	2.14	
HZY2-250	90.3	66.6	53.8	45.5	39.4	31.2	25.8	22.0	11.8	6.25	4.29	3.17	2.66	
HZY2-300	108	79.3	64.2	54.1	46.9	37.2	30.7	26.2	14.0	7.43	5.12	3.77	3.17	
HZY2-375	135	100	80.5	67.8	58.5	46.1	38.0	32.5	17.4	9.38	6.50	4.81	4.03	
HZY2-400	145	108	86.6	72.8	63.2	49.9	41.5	35.4	18.9	10.00	6.91	5.10	4.27	
HZY2-450	163	120	97.0	81.8	71.1	56.5	46.7	39.9	21.2	11.2	7.76	5.75	4.83	
HZY2-500	181	134	108	91.3	79.2	63.0	52.3	44.4	23.5	12.5	8.64	6.40	5.37	
HZY2-575	205	153	123	104	90.3	71.8	59.6	50.6	27.2	14.2	9.79	7.23	6.08	
HZY2-600	217	161	130	109	94.8	74.8	61.8	52.8	28.4	15.0	10.36	7.61	6.39	
HZY2-625	225	167	134	113	98.5	78.0	64.8	55.2	29.6	15.7	10.76	7.94	6.67	
HZY2-750	271	202	163	137	119	94.8	78.3	66.5	35.3	18.7	13.0	9.63	8.06	
HZY2-800	289	215	173	146	127	100.6	82.8	70.4	37.6	20.0	13.8	10.17	8.55	
HZY2-1000	360	268	215	182	158	126	104	88.7	47.0	24.8	17.0	12.6	10.58	
HZY2-1250	451	337	272	229	198	158	131	111	58.7	31.3	21.5	15.8	13.3	
HZY2-1500	541	402	325	274	237	188	155	132	70.2	37.2	25.8	19.1	16.0	
HZY2-1875	677	507	407	342	297	236	196	167	88.5	46.9	32.3	23.6	19.8	
HZY2-2000	721	536	431	364	316	249	206	175	93.8	49.8	34.2	25.2	21.1	
HZY2-2500	900	670	541	455	396	313	259	220	118	62.5	42.5	31.1	26.2	
HZY2-3000	1083	807	649	549	475	376	311	265	142	75.0	51.3	37.6	31.6	
HZY2-3850	1390	1032	833	701	610	481	399	340	182	95.7	65.3	47.7	40.0	

Battery Model	Time in Hours Ah to 1.85 VPC												
	2	3	4	5	6	8	10	12	24	48	72	100	120
HZY2-50	32.4	36.1	38.8	41.0	42.7	45.5	47.0	48.0	52.3	55.5	56.9	57.8	58.1
HZY2-100	65.6	72.6	77.8	82.2	85.6	90.8	94.0	95.9	103	109	113	116	117
HZY2-150	97.2	109	117	123	128	137	141	144	155	162	167	171	172
HZY2-200	131	144	155	165	172	183	189	193	208	220	227	232	233
HZY2-250	163	182	195	205	215	227	236	241	260	275	282	289	291
HZY2-300	196	218	234	246	257	273	283	289	310	328	339	346	348
HZY2-375	244	270	292	309	322	340	353	361	387	413	429	435	437
HZY2-400	261	290	311	329	342	360	375	384	410	439	455	464	466
HZY2-450	294	326	348	368	385	408	422	432	460	488	505	519	522
HZY2-500	326	365	391	412	429	455	472	481	513	543	562	580	584
HZY2-575	372	410	440	466	489	518	538	548	589	618	637	655	662
HZY2-600	392	437	466	493	514	541	563	577	625	656	674	685	689
HZY2-625	407	451	484	512	533	567	590	602	648	679	697	715	721
HZY2-750	490	545	583	618	645	684	707	721	771	817	851	869	874
HZY2-800	522	581	626	663	692	735	755	770	825	873	904	927	934
HZY2-1000	651	720	775	822	857	910	943	962	1036	1085	1118	1135	1140
HZY2-1250	814	909	980	1035	1078	1140	1180	1200	1286	1356	1400	1426	1435
HZY2-1500	977	1086	1170	1233	1285	1366	1404	1440	1546	1627	1681	1714	1723
HZY2-1875	1223	1358	1456	1540	1606	1704	1770	1800	1934	2034	2097	2129	2138
HZY2-2000	1304	1446	1559	1651	1729	1835	1890	1937	2084	2217	2274	2314	2328
HZY2-2500	1630	1806	1943	2048	2134	2277	2360	2415	2587	2712	2760	2799	2816
HZY2-3000	1956	2162	2330	2467	2574	2731	2830	2892	3114	3255	3322	3378	3405
HZY2-3850	2511	2793	3002	3163	3303	3513	3630	3708	3960	4177	4267	4324	4357

Battery Model	Time in Hours Ah to 1.80 VPC												
	2	3	4	5	6	8	10	12	24	48	72	100	120
HZY2-50	34.5	38.4	41.2	43.7	45.5	48.1	50.0	51.1	55.0	58.0	60.0	61.2	61.8
HZY2-100	69.0	77.0	82.6	87.2	91.1	96.2	99.4	102	110	117	120	123	125
HZY2-150	104	115	124	131	137	145	150	153	164	172	178	183	185
HZY2-200	139	154	165	175	183	195	201	206	219	231	238	244	246
HZY2-250	174	193	207	219	227	240	248	254	273	288	297	304	306
HZY2-300	207	231	248	261	271	286	297	303	323	343	356	366	368
HZY2-375	258	288	311	328	340	359	371	380	406	433	450	463	465
HZY2-400	278	309	332	350	364	385	400	410	434	463	479	490	492
HZY2-450	312	347	372	392	409	431	445	454	487	518	537	555	558
HZY2-500	347	385	414	438	457	485	502	512	544	578	598	616	621
HZY2-575	396	439	470	501	521	552	572	583	623	657	681	700	707
HZY2-600	413	462	497	525	547	576	596	611	658	689	710	725	730
HZY2-625	432	481	514	540	564	599	622	637	683	722	745	766	770
HZY2-750	521	578	618	656	686	726	752	767	815	865	901	926	930
HZY2-800	553	617	663	700	732	779	803	820	871	927	964	988	993
HZY2-1000	692	768	823	875	912	967	1003	1024	1099	1153	1189	1219	1227
HZY2-1250	866	963	1035	1096	1143	1209	1255	1277	1357	1443	1489	1524	1534
HZY2-1500	1039	1146	1237	1313	1368	1442	1487	1522	1626	1719	1788	1832	1846
HZY2-1875	1301	1444	1547	1634	1710	1811	1883	1915	2054	2164	2231	2266	2279
HZY2-2000	1377	1541	1653	1748	1829	1937	1992	2033	2172	2309	2368	2423	2445
HZY2-2500	1727	1925	2074	2193	2283	2426	2501	2554	2730	2885	2936	2982	2999
HZY2-3000	2081	2313	2476	2627	2738	2905	3002	3065	3287	3447	3530	3586	3614
HZY2-3850	2671	2983	3197	3366	3516	3700	3840	3920	4180	4430	4520	4590	4620

Battery Model	Time in Hours Ah to 1.75 VPC												
	2	3	4	5	6	8	10	12	24	48	72	100	120
HZY2-50	35.3	39.1	41.8	44.5	46.4	49.3	51.0	52.1	56.4	59.9	62.1	63.3	64.0
HZY2-100	71.8	80.4	86.2	91.1	94.8	101	104	106	114	121	125	128	130
HZY2-150	108	120	129	136	142	150	155	158	170	179	185	190	192
HZY2-200	145	161	172	182	190	202	209	214	227	240	248	254	257
HZY2-250	181	200	215	228	236	249	258	264	282	300	309	317	319
HZY2-300	215	238	257	270	282	297	307	315	336	357	369	377	380
HZY2-375	270	299	322	339	351	369	380	390	418	450	468	481	484
HZY2-400	289	323	346	364	379	399	415	425	454	480	498	510	512
HZY2-450	325	360	388	409	426	452	467	478	509	540	559	575	579
HZY2-500	361	402	433	456	475	504	523	533	565	601	622	640	644
HZY2-575	410	458	492	519	542	574	596	607	652	684	705	723	729
HZY2-600	434	482	519	547	569	598	618	634	682	720	746	761	767
HZY2-625	451	502	537	566	591	624	648	662	710	751	775	794	800
HZY2-750	542	605	652	686	714	758	783	799	848	899	937	963	967
HZY2-800	578	646	694	730	761	805	828	845	902	960	996	1017	1026
HZY2-1000	720	804	858	910	950	1004	1044	1064	1127	1188	1227	1258	1269
HZY2-1250	901	1011	1089	1144	1189	1260	1306	1329	1409	1500	1549	1583	1592
HZY2-1500	1082	1206	1300	1368	1424	1501	1548	1581	1685	1785	1860	1913	1924
HZY2-1875	1354	1520	1629	1709	1779	1886	1956	2001	2124	2250	2323	2359	2372
HZY2-2000	1443	1607	1725	1821	1895	1992	2056	2098	2250	2388	2463	2517	2536
HZY2-2500	1799	2011	2165	2277	2376	2507	2593	2644	2833	3001	3062	3114	3147
HZY2-3000	2165	2420	2596	2743	2850	3009	3107	3183	3405	3601	3693	3760	3787
HZY2-3850	2780	3096	3332	3503	3659	3850	3990	4080	4360	4594	4698	4774	4802

Battery Model	Time in Minutes - Amps to 1.70 VPC						
	15	20	25	30	45	60	90
HZY2-50	77.8	66.7	58.2	51.6	39.1	31.3	22.7
HZY2-100	159	134	117	104	78.8	63.1	45.8
HZY2-150	227	193	169	151	114	92.8	68.3
HZY2-200	260	227	206	190	151	123	91.4
HZY2-250	319	286	258	236	188	154	115
HZY2-300	388	341	307	279	223	183	136
HZY2-375	479	423	385	348	279	230	171
HZY2-400	519	457	414	378	300	246	183
HZY2-450	591	523	468	425	335	277	205
HZY2-500	661	579	523	472	374	306	228
HZY2-575	732	646	589	539	428	349	258
HZY2-600	762	685	621	568	449	371	274
HZY2-625	802	710	643	582	458	379	283
HZY2-750	960	852	779	710	563	461	342
HZY2-800	1028	913	828	756	600	491	364
HZY2-1000	1280	1134	1039	945	744	610	455
HZY2-1250	1568	1392	1253	1150	919	758	565
HZY2-1500	1876	1686	1529	1392	1105	911	681
HZY2-1875	2376	2118	1910	1746	1391	1142	854
HZY2-2000	2512	2220	2009	1848	1484	1224	906
HZY2-2500	3184	2832	2551	2336	1863	1537	1141
HZY2-3000	3860	3408	3060	2786	2236	1841	1371
HZY2-3850	4760	4227	3818	3494	2808	2331	1749

Battery Model	Time in Hours				Amps to 1.70 VPC				
	2	3	4	5	6	8	10	12	24
HZY2-50	18.0	13.2	10.7	9.03	7.86	6.31	5.20	4.43	2.41
HZY2-100	36.6	27.1	21.8	18.4	16.1	12.9	10.61	9.02	4.92
HZY2-150	55.1	40.8	32.8	27.8	24.1	19.3	15.9	13.6	7.39
HZY2-200	73.7	54.4	43.8	37.1	32.2	25.8	21.3	18.2	9.91
HZY2-250	92.1	67.9	54.9	46.3	40.0	32.2	26.6	22.6	12.3
HZY2-300	109	81.8	66.2	56.1	48.6	38.5	31.9	27.1	14.7
HZY2-375	138	102	82.4	69.9	60.5	48.4	40.0	34.0	18.5
HZY2-400	147	110	87.7	74.2	64.2	51.6	42.6	36.1	19.8
HZY2-450	166	122	98.5	83.2	72.2	58.0	47.9	40.7	22.3
HZY2-500	184	136	110	93.3	80.5	64.6	53.3	45.3	24.7
HZY2-575	210	157	126	106	92	73.6	60.8	51.6	28.1
HZY2-600	221	164	132	111	96	77.4	63.9	54.3	29.7
HZY2-625	230	171	137	116	100	80.7	66.6	56.7	30.9
HZY2-750	276	207	166	140	121	96.7	79.8	67.9	37.0
HZY2-800	295	219	176	149	129	103	85.3	72.5	39.5
HZY2-1000	367	275	221	186	161	129	106	90.6	49.5
HZY2-1250	460	344	277	234	202	161	133	113	61.8
HZY2-1500	552	413	332	279	241	194	160	136	74.2
HZY2-1875	690	517	416	349	301	242	200	169	92.7
HZY2-2000	736	551	442	373	323	258	213	181	98.9
HZY2-2500	920	689	553	466	403	323	267	226	123
HZY2-3000	1104	827	663	560	483	387	320	272	148
HZY2-3850	1418	1061	848	715	620	497	410	349	191

Battery Model	Time in Hours Ah to 1.70 VPC								
	2	3	4	5	6	8	10	12	24
HZY2-50	36.0	39.7	42.9	45.1	47.3	50.0	51.7	52.6	57.0
HZY2-100	73.3	81.3	87.5	92.2	96.7	102	106	108	115
HZY2-150	110	122	131	139	144	152	157	161	172
HZY2-200	147	163	175	185	193	205	211	215	229
HZY2-250	184	204	220	231	240	252	261	267	285
HZY2-300	219	243	262	275	287	303	313	320	340
HZY2-375	275	305	327	343	355	374	386	395	423
HZY2-400	295	329	352	371	387	406	422	434	463
HZY2-450	332	366	394	416	435	460	475	485	517
HZY2-500	368	409	439	464	482	511	529	540	573
HZY2-575	421	470	504	532	553	587	605	618	664
HZY2-600	442	491	527	555	576	607	626	643	692
HZY2-625	460	513	548	577	601	633	656	672	720
HZY2-750	553	616	663	700	728	772	798	815	861
HZY2-800	590	657	706	743	777	818	840	857	919
HZY2-1000	735	825	884	931	970	1025	1065	1087	1146
HZY2-1250	919	1032	1107	1168	1212	1282	1330	1353	1432
HZY2-1500	1103	1239	1330	1399	1452	1529	1576	1610	1712
HZY2-1875	1381	1551	1663	1745	1815	1912	1983	2033	2155
HZY2-2000	1472	1634	1756	1857	1929	2029	2089	2136	2288
HZY2-2500	1840	2053	2211	2332	2423	2552	2633	2684	2873
HZY2-3000	2209	2470	2653	2801	2907	3058	3162	3231	3461
HZY2-3850	2835	3161	3400	3561	3712	3910	4040	4130	4430

HAZE Watts Per Cell Data

Battery Model	Time in Minutes - Watts per cell to 1.85 VPC						
	15	20	25	30	45	60	90
HZY2-50	120	105	93.4	84.5	65.8	53.3	39.3
HZY2-100	251	216	189	169	130	107	79.5
HZY2-150	339	300	267	243	189	153	114
HZY2-200	382	348	326	302	247	206	155
HZY2-250	467	435	402	372	302	252	193
HZY2-300	551	509	470	442	364	304	231
HZY2-375	684	630	590	555	463	387	292
HZY2-400	764	697	638	598	489	409	310
HZY2-450	860	787	727	680	549	461	348
HZY2-500	940	867	806	756	616	516	386
HZY2-575	1060	979	914	852	703	589	440
HZY2-600	1104	1022	947	878	731	611	463
HZY2-625	1148	1053	974	908	760	637	482
HZY2-750	1380	1291	1206	1128	912	761	582
HZY2-800	1452	1376	1285	1192	973	812	616
HZY2-1000	1876	1734	1599	1492	1232	1021	771
HZY2-1250	2348	2150	2004	1866	1528	1273	963
HZY2-1500	2828	2610	2443	2276	1860	1540	1165
HZY2-1875	3480	3219	2988	2780	2279	1910	1445
HZY2-2000	3716	3441	3197	2990	2441	2031	1539
HZY2-2500	4528	4262	3953	3690	3019	2545	1941
HZY2-3000	5216	4920	4672	4400	3663	3070	2307
HZY2-3850	7000	6470	5940	5560	4600	3890	2973

Battery Model	Time in Minutes - Watts per cell to 1.80 VPC						
	15	20	25	30	45	60	90
HZY2-50	130	114	101	90.8	69.9	56.8	41.5
HZY2-100	266	231	204	182	140	113	83.1
HZY2-150	374	325	287	259	199	163	122
HZY2-200	417	379	352	325	266	219	163
HZY2-250	513	467	437	403	320	267	205
HZY2-300	616	554	511	478	388	326	247
HZY2-375	771	699	643	598	485	404	307
HZY2-400	833	750	689	640	517	437	329
HZY2-450	952	858	782	732	584	488	370
HZY2-500	1044	945	876	813	663	546	410
HZY2-575	1170	1062	984	910	749	622	469
HZY2-600	1232	1119	1032	952	779	654	493
HZY2-625	1285	1170	1075	994	815	678	510
HZY2-750	1540	1404	1297	1208	972	807	611
HZY2-800	1600	1480	1381	1280	1037	871	653
HZY2-1000	2068	1872	1720	1592	1305	1091	819
HZY2-1250	2596	2337	2159	2000	1624	1359	1018
HZY2-1500	3081	2814	2601	2406	1956	1629	1233
HZY2-1875	3800	3504	3245	3006	2451	2027	1526
HZY2-2000	4108	3750	3482	3228	2607	2168	1643
HZY2-2500	4928	4582	4251	3966	3221	2700	2053
HZY2-3000	6064	5577	5184	4826	3913	3277	2453
HZY2-3850	7908	7150	6576	6080	5000	4180	3154

Battery Model	Time in Minutes - Watts per cell to 1.75 VPC						
	15	20	25	30	45	60	90
HZY2-50	137	119	105	94.1	71.3	58.2	42.7
HZY2-100	276	238	210	188	144	117	85.8
HZY2-150	391	341	304	272	208	171	129
HZY2-200	447	402	366	337	274	228	172
HZY2-250	552	496	458	423	337	281	213
HZY2-300	670	603	550	505	407	342	258
HZY2-375	835	748	680	628	505	424	319
HZY2-400	904	809	732	676	541	456	344
HZY2-450	1036	913	828	766	613	510	386
HZY2-500	1136	1018	936	861	685	567	426
HZY2-575	1264	1140	1044	962	780	646	485
HZY2-600	1336	1203	1104	1018	822	687	516
HZY2-625	1360	1242	1135	1044	851	711	533
HZY2-750	1680	1520	1395	1280	1021	851	640
HZY2-800	1736	1584	1459	1344	1087	911	685
HZY2-1000	2212	1986	1814	1674	1360	1138	852
HZY2-1250	2804	2514	2285	2094	1700	1418	1063
HZY2-1500	3248	2979	2731	2514	2035	1700	1282
HZY2-1875	4096	3735	3425	3152	2565	2124	1593
HZY2-2000	4412	4011	3665	3392	2732	2265	1707
HZY2-2500	5368	4896	4510	4172	3369	2817	2144
HZY2-3000	6652	6015	5520	5086	4105	3440	2580
HZY2-3850	8400	7590	6912	6380	5173	4350	3293

Battery Model	Time in Hours Watts per cell to 1.85 VPC												
	2	3	4	5	6	8	10	12	24	48	72	100	120
HZY2-50	31.7	23.6	19.0	16.1	14.0	11.2	9.37	8.00	4.37	2.32	1.60	1.16	0.97
HZY2-100	64.0	47.7	38.5	32.6	28.4	22.7	18.9	16.1	8.6	4.57	3.15	2.33	1.96
HZY2-150	93.5	70.5	57.2	48.6	42.2	33.5	28.0	23.9	12.9	6.81	4.69	3.43	2.87
HZY2-200	126	93.6	76.0	64.9	56.5	45.0	37.7	32.2	17.4	9.19	6.32	4.66	3.90
HZY2-250	158	117	95.3	80.6	70.4	56.3	47.1	40.2	21.7	11.5	7.88	5.79	4.87
HZY2-300	189	141	115	97.4	84.8	67.3	56.4	48.2	25.9	13.7	9.42	6.96	5.85
HZY2-375	236	175	142	121	106	84.6	70.6	60.2	32.3	17.3	11.9	8.73	7.31
HZY2-400	252	188	153	128	112	89.2	74.7	64.0	34.2	18.3	12.7	9.27	7.80
HZY2-450	284	212	171	145	126	101	84.5	72.0	38.4	20.4	14.0	10.3	8.63
HZY2-500	315	237	192	162	141	113	94.1	80.2	42.8	22.7	15.7	11.6	9.74
HZY2-575	360	267	215	184	161	128	107	91.4	49.2	25.8	17.8	13.0	10.9
HZY2-600	379	284	229	194	169	135	113	96.2	51.8	27.3	18.5	13.5	11.3
HZY2-625	393	296	237	202	175	140	117	100	54.3	28.7	19.7	14.5	12.2
HZY2-750	473	354	286	243	212	170	141	120	64.4	34.1	23.7	17.4	14.6
HZY2-800	505	377	307	261	227	180	151	128	68.9	37.0	25.5	18.8	15.7
HZY2-1000	629	468	380	324	281	225	188	160	86.5	45.4	31.2	22.8	19.1
HZY2-1250	787	590	481	408	352	281	235	200	107	56.7	39.0	28.6	23.9
HZY2-1500	948	708	574	486	424	340	283	240	129	68.0	46.7	34.2	28.7
HZY2-1875	1182	882	714	603	527	424	353	300	162	85.0	58.1	42.7	35.8
HZY2-2000	1260	940	760	651	568	455	377	320	172	92.7	63.6	46.4	39.0
HZY2-2500	1575	1173	948	807	705	562	471	400	215	113	77.1	56.6	47.4
HZY2-3000	1891	1405	1143	972	845	673	564	482	261	137	93.5	68.4	57.3
HZY2-3850	2427	1832	1480	1246	1084	866	724	618	336	175	119	86.8	72.8

Battery Model	Time in Hours Watts per cell to 1.80 VPC												
	2	3	4	5	6	8	10	12	24	48	72	100	120
HZY2-50	33.4	25.0	20.2	17.2	14.9	11.9	9.97	8.51	4.65	2.46	1.69	1.23	1.03
HZY2-100	66.9	50.0	40.5	34.4	29.9	23.9	19.9	17.0	9.1	4.82	3.34	2.48	2.07
HZY2-150	99.5	74.5	60.7	51.6	44.9	35.6	29.8	25.5	13.8	7.24	4.98	3.64	3.05
HZY2-200	134	99.8	81.1	68.9	60.0	47.6	39.9	34.1	18.4	9.73	6.72	4.95	4.15
HZY2-250	168	125	101	86.2	75.0	59.5	49.8	42.5	22.8	12.1	8.28	6.10	5.13
HZY2-300	201	150	122	104	89.9	71.1	59.6	50.8	27.3	14.5	10.0	7.35	6.16
HZY2-375	251	187	152	128	112	89.1	74.2	63.3	33.8	18.1	12.5	9.20	7.72
HZY2-400	268	201	163	138	120	95.1	79.4	68.1	36.5	19.4	13.4	9.91	8.30
HZY2-450	302	226	183	155	134	107	89.9	76.6	40.5	21.7	15.0	11.0	9.23
HZY2-500	335	250	203	172	150	119	100	85.3	45.5	24.1	16.7	12.3	10.3
HZY2-575	383	285	231	196	171	137	114	97.2	52.0	27.5	19.0	13.9	11.7
HZY2-600	401	300	243	206	179	143	120	102	54.9	28.9	19.8	14.5	12.2
HZY2-625	418	313	254	214	186	149	125	106	57.6	30.3	20.8	15.3	12.9
HZY2-750	503	376	303	259	225	180	149	127	68.1	36.1	25.1	18.5	15.5
HZY2-800	537	401	325	276	240	191	160	137	72.7	38.9	26.7	19.7	16.6
HZY2-1000	669	499	404	343	300	239	200	171	91.7	48.2	33.1	24.3	20.3
HZY2-1250	834	626	508	432	375	300	250	213	114	60.3	41.4	30.6	25.6
HZY2-1500	1005	748	607	514	449	360	301	255	137	71.8	49.3	36.3	30.4
HZY2-1875	1250	938	759	644	561	448	375	319	171	90.4	62.2	45.8	38.4
HZY2-2000	1340	1001	811	689	600	479	398	338	180	96.5	66.5	48.6	40.9
HZY2-2500	1667	1251	1013	858	749	597	496	423	225	119	81.1	59.5	50.2
HZY2-3000	2011	1503	1215	1035	899	718	600	513	275	145	98.9	72.5	60.9
HZY2-3850	2575	1938	1568	1326	1154	917	770	657	356	186	127	92.5	77.6

Battery Model	Time in Hours Watts per cell to 1.75 VPC												
	2	3	4	5	6	8	10	12	24	48	72	100	120
HZY2-50	34.1	25.4	20.5	17.5	15.2	12.2	10.2	8.72	4.74	2.51	1.72	1.26	1.05
HZY2-100	69.2	51.7	41.9	35.7	31.1	24.7	20.6	17.5	9.4	5.01	3.47	2.58	2.18
HZY2-150	104	78.1	63.2	53.5	46.5	36.9	30.8	26.4	14.4	7.56	5.21	3.81	3.19
HZY2-200	140	104	84.6	71.7	62.3	49.4	41.1	35.2	18.9	10.0	6.93	5.13	4.31
HZY2-250	174	130	106	89.7	78.0	61.9	51.7	44.2	23.7	12.6	8.65	6.36	5.35
HZY2-300	209	156	127	108	93.5	73.8	61.8	52.5	28.0	14.9	10.3	7.58	6.38
HZY2-375	261	194	158	133	116	91.7	76.5	65.3	35.0	18.8	13.0	9.55	8.00
HZY2-400	279	210	170	143	124	99.0	82.5	70.4	37.6	20.1	13.9	10.3	8.58
HZY2-450	314	233	189	161	140	112	93.6	79.7	42.0	22.6	15.6	11.5	9.58
HZY2-500	348	260	211	179	156	124	104	88.8	47.1	25.0	17.3	12.8	10.7
HZY2-575	398	299	241	205	178	142	119	101	53.9	28.6	19.6	14.5	12.1
HZY2-600	419	313	255	215	187	149	125	107	57.6	30.4	20.8	15.3	12.8
HZY2-625	435	325	263	222	193	154	130	111	60.0	31.7	21.8	16.1	13.5
HZY2-750	524	390	317	269	234	186	156	132	70.0	37.4	25.9	19.1	16.0
HZY2-800	559	421	340	287	249	197	164	140	75.3	40.1	27.7	20.4	17.2
HZY2-1000	696	522	421	357	312	249	208	178	95.1	50.1	34.5	25.3	21.2
HZY2-1250	870	657	534	451	392	312	260	221	118	62.7	43.3	32.0	26.8
HZY2-1500	1045	782	635	535	467	375	313	266	141	74.6	51.4	37.9	31.8
HZY2-1875	1300	988	799	674	584	464	391	332	177	94.0	64.7	47.6	39.9
HZY2-2000	1395	1044	846	718	625	496	411	350	186	100	69.1	50.7	42.6
HZY2-2500	1744	1307	1062	898	783	621	517	440	234	124	84.9	62.4	52.3
HZY2-3000	2093	1572	1271	1076	935	741	615	524	281	149	102	74.9	62.8
HZY2-3850	2686	2017	1634	1380	1201	958	801	684	368	193	132	97.1	81.3

HAZE Watts Per Cell Data

Battery Model	Time in Minutes - Watts per cell to 1.70 VPC						
	15	20	25	30	45	60	90
HZY2-50	141	122	107	96.0	72.8	59.2	43.5
HZY2-100	284	246	217	194	148	120	87.4
HZY2-150	404	351	310	278	212	175	131
HZY2-200	470	419	381	350	280	233	175
HZY2-250	578	520	475	435	347	288	218
HZY2-300	698	623	561	515	415	345	260
HZY2-375	872	778	710	649	520	435	326
HZY2-400	939	834	756	693	553	463	349
HZY2-450	1084	951	855	790	628	520	393
HZY2-500	1172	1047	955	879	699	582	436
HZY2-575	1340	1188	1078	988	795	662	495
HZY2-600	1416	1265	1147	1050	846	705	524
HZY2-625	1420	1287	1171	1072	872	728	546
HZY2-750	1763	1566	1423	1308	1047	867	651
HZY2-800	1832	1662	1522	1390	1116	933	700
HZY2-1000	2312	2061	1869	1724	1395	1160	873
HZY2-1250	2908	2583	2336	2140	1731	1440	1085
HZY2-1500	3376	3087	2844	2608	2090	1741	1308
HZY2-1875	4256	3858	3511	3234	2616	2168	1631
HZY2-2000	4588	4158	3782	3490	2793	2306	1739
HZY2-2500	5644	5079	4675	4296	3455	2871	2191
HZY2-3000	6944	6251	5712	5234	4187	3505	2632
HZY2-3850	8720	7830	7128	6560	5333	4450	3359

Battery Model	Time in Hours Watts per cell to 1.70 VPC								
	2	3	4	5	6	8	10	12	24
HZY2-50	34.8	25.8	20.9	17.8	15.5	12.4	10.3	8.82	4.80
HZY2-100	70.5	52.6	42.7	36.3	31.5	25.0	20.8	17.7	9.5
HZY2-150	106	79.5	64.3	54.5	47.2	37.3	31.2	26.7	14.6
HZY2-200	142	106	86.0	72.6	63.2	49.9	41.5	35.5	19.1
HZY2-250	178	132	107	90.8	79.0	62.9	52.5	44.8	23.9
HZY2-300	212	159	129	109	94.8	74.8	62.4	53.1	28.4
HZY2-375	266	198	161	136	117	92.9	77.4	65.9	35.4
HZY2-400	285	214	172	145	126	101	84.0	71.5	38.3
HZY2-450	321	238	193	164	143	114	94.9	80.8	42.7
HZY2-500	356	266	215	183	159	126	106	90.3	47.8
HZY2-575	406	305	247	208	181	144	121	103	54.7
HZY2-600	427	319	259	218	190	151	126	108	58.4
HZY2-625	444	333	270	227	197	157	132	113	61.3
HZY2-750	532	397	322	273	238	188	158	134	71.0
HZY2-800	570	427	346	292	252	200	167	142	76.8
HZY2-1000	710	533	433	365	318	253	211	180	96.9
HZY2-1250	886	670	544	459	398	317	265	225	120
HZY2-1500	1066	797	645	545	476	380	318	270	143
HZY2-1875	1332	1007	816	687	596	474	399	339	180
HZY2-2000	1422	1065	862	729	636	503	416	355	189
HZY2-2500	1779	1333	1084	919	798	631	526	448	238
HZY2-3000	2135	1611	1301	1096	952	754	626	533	288
HZY2-3850	2740	2053	1663	1409	1225	975	817	698	376

Battery Model	Time in Minutes - Watts per cell to 1.65 VPC						
	15	20	25	30	45	60	90
HZY2-50	143	125	109	97.0	74.4	60.2	44.3
HZY2-100	292	251	222	198	151	122	88.7
HZY2-150	414	359	317	283	218	177	133
HZY2-200	494	434	394	359	287	237	178
HZY2-250	604	541	492	449	356	293	221
HZY2-300	718	639	578	530	425	351	265
HZY2-375	907	804	734	668	531	443	333
HZY2-400	973	862	779	712	564	471	354
HZY2-450	1144	989	890	812	642	530	401
HZY2-500	1212	1080	979	896	711	590	440
HZY2-575	1396	1236	1114	1012	815	678	507
HZY2-600	1468	1302	1174	1070	863	718	537
HZY2-625	1488	1320	1198	1098	893	743	555
HZY2-750	1816	1614	1465	1340	1072	885	663
HZY2-800	1912	1729	1565	1430	1145	954	715
HZY2-1000	2384	2124	1922	1760	1424	1180	885
HZY2-1250	3012	2657	2395	2184	1756	1458	1099
HZY2-1500	3480	3174	2904	2666	2133	1776	1331
HZY2-1875	4400	3966	3600	3293	2655	2207	1667
HZY2-2000	4696	4254	3847	3554	2840	2347	1771
HZY2-2500	5864	5247	4759	4391	3524	2933	2241
HZY2-3000	7172	6456	5870	5348	4267	3571	2667
HZY2-3850	9080	8130	7320	6720	5427	4530	3427

Battery Model	Dimensions (mm) & weight (Kg)				Dimensions (Inches) & weight (lbs)				No. of Terminals	Internal Resistance mOhms	Maximum Charge Current	Short Circuit Current
	Length	Width	Height	Weight	Length	Width	Height	Weight				
HZY2-50	161	50	166	3.8	6.34	1.97	6.54	8.4	2	2.1	10	509
HZY2-100	171	72	205	6.42	6.73	2.83	8.07	14.2	2	2	20	1080
HZY2-150	172	102	205	10	6.77	4.02	8.07	22.1	2	1.5	30	1550
HZY2-200	173	111	329	14	6.81	4.37	12.95	30.9	2	0.5	40	1600
HZY2-250	173	111	329	16.3	6.81	4.37	12.95	36.0	2	0.45	50	2000
HZY2-300	171	151	330	18.7	6.73	5.94	12.99	41.3	2	0.4	60	2400
HZY2-375	171	151	330	23.5	6.73	5.94	12.99	51.9	2	0.39	75	3000
HZY2-400	211	176	329	26.2	8.31	6.93	12.95	57.9	4	0.36	80	3200
HZY2-450	223	187	351	32	8.78	7.36	13.82	70.7	4	0.33	90	3600
HZY2-500-1	211	176	329	32.3	8.31	6.93	12.95	71.4	4	0.3	100	4000
HZY2-500-2	241	172	331	30.9	9.49	6.77	13.03	68.3	4	0.3	100	4000
HZY2-575	223	187	351	36.5	8.78	7.36	13.82	80.7	4	0.29	115	4600
HZY2-600	301	175	331	38.8	11.85	6.89	13.03	85.7	4	0.28	120	4800
HZY2-625	241	172	331	39	9.49	6.77	13.03	86.2	4	0.25	125	5000
HZY2-750	301	175	331	51	11.85	6.89	13.03	112.7	4	0.22	130	6000
HZY2-800	410	175	330	52	16.14	6.89	12.99	114.9	8	0.2	160	6400
HZY2-1000-1	410	175	330	60.9	16.14	6.89	12.99	134.6	8	0.16	200	7900
HZY2-1000-2	475	175	328	63	18.70	6.89	12.91	139.2	8	0.16	200	7900
HZY2-1250	475	175	328	71.6	18.70	6.89	12.91	158.2	8	0.13	250	10050
HZY2-1500	401	351	342	103	15.79	13.82	13.46	227.6	8	0.11	300	11950
HZY2-1875	401	351	342	118	15.79	13.82	13.46	260.8	8	0.1	375	15050
HZY2-2000	491	351	344	132	19.33	13.82	13.54	291.7	8	0.09	400	16100
HZY2-2500	491	351	344	175	19.33	13.82	13.54	386.8	8	0.08	500	19850
HZY2-3000	762	353	341	211	30.00	13.90	13.43	466.3	8	0.08	600	24100
HZY2-3850	762	353	341	261	30.00	13.90	13.43	576.8	8	0.07	770	30800

The graph shows extrapolated Service Life condition for Haze batteries at different ambient temperatures. Clearly higher ambient temperatures will reduce service life.

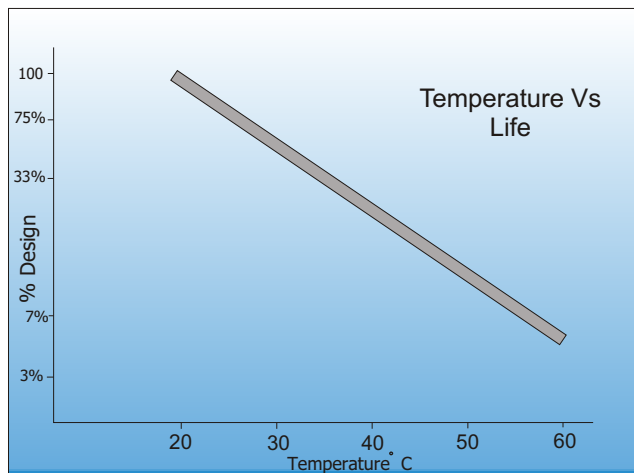

Temperature	Shelf Life
0 °C - 20 °C (32 °F - 68 °F)	12 Months
21 °C - 30 °C (69 °F - 86 °F)	9 Months
31 °C - 40 °C (87 °F - 104 °F)	5 Months
41 °C - 50 °C (105 °F - 1122 °F)	2.5 Months

CHARGING CHARACTERISTICS

Floating - The optimum float voltage for a battery is temperature dependant, at 15 - 24°C the recommended value is 2.27 - 2.30V. It is recommended that battery installation sites are temperature controlled, however float voltage can be increased or decreased to compensate for temperature variations. Adjustment is calculated at +/- 3 mV per degree C.

The most suitable charging method for battery life and performance is the constant voltage method with a limited initial current, usually limited to a maximum of $C_{20}/4$.

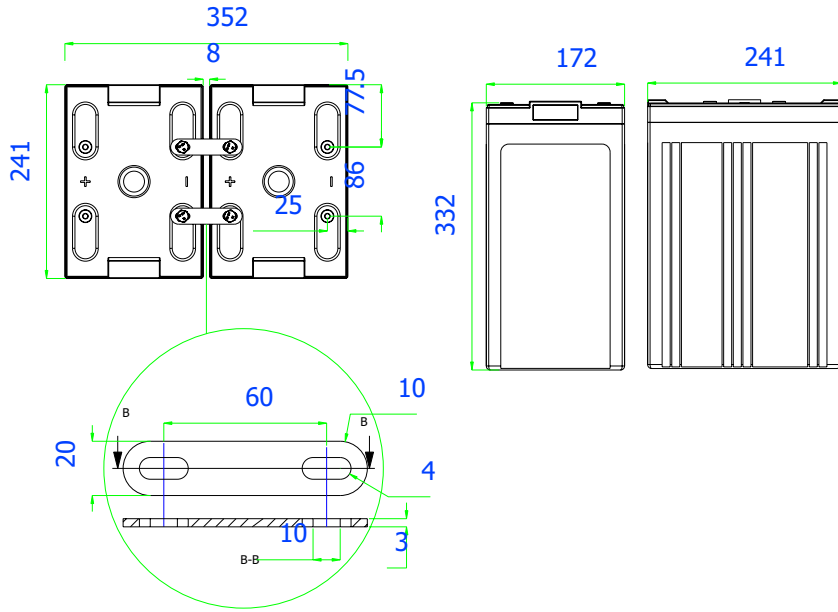

The sample battery layout drawings shown are available for all models showing terminal locations and intercell and inter battery connections. We can provide custom layouts to customers with an existing installation or footprint limitations.

Battery spacing is flexible to allow greater or smaller spacing between the cells, indeed our standard connector has 10mm of travel allowing battery spacing from 3 to 13 mm. Close spacing is only recommended in temperature controlled environments with forced cooling. Connectors and terminal covers are supplied as standard.

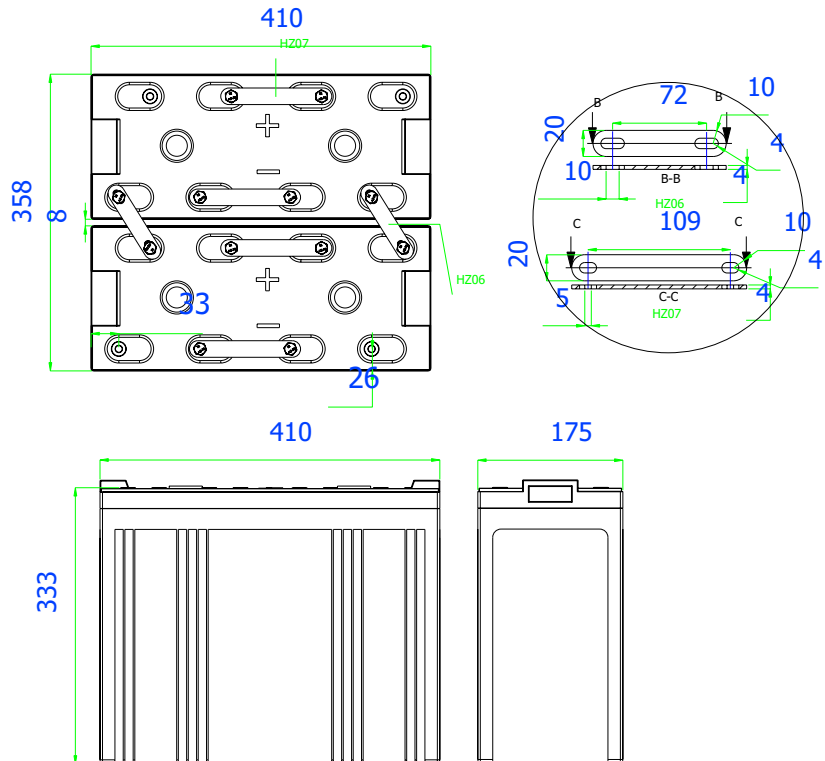

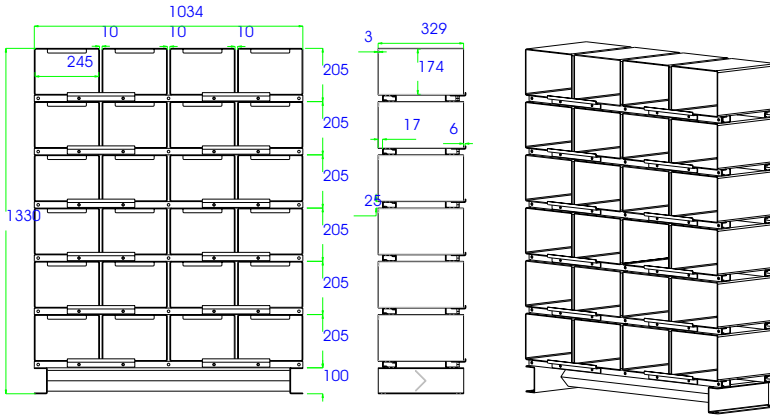

RACKING OPTIONS - Many racking options are available from Haze Battery Company. The favored style in Europe is the open rack, which can be designed to suit an existing foot print or minimised to fit the minimum possible space. Rack construction is from heavy duty steel section with welded joints or alternatively made in kit form for remote assembly.

A modular rack is also available for models HZY2-200 up to HZY2-1250. Box construction is from 3mm steel sheet, interlocking modules are slotted together and bolted in place, bolted front retainers hold the batteries in place resulting in a seismic zone 4 classified rack.

HZY2-1500 and above, due to their size and weight are more suited to vertical orientation - racking can be supplied to minimise the footprint by the use of multiple tiers. Battery retainers can be utilised to allow seismic zone 4 classification. Racks can be supplied with welded joints or as kit form for remote assembly.

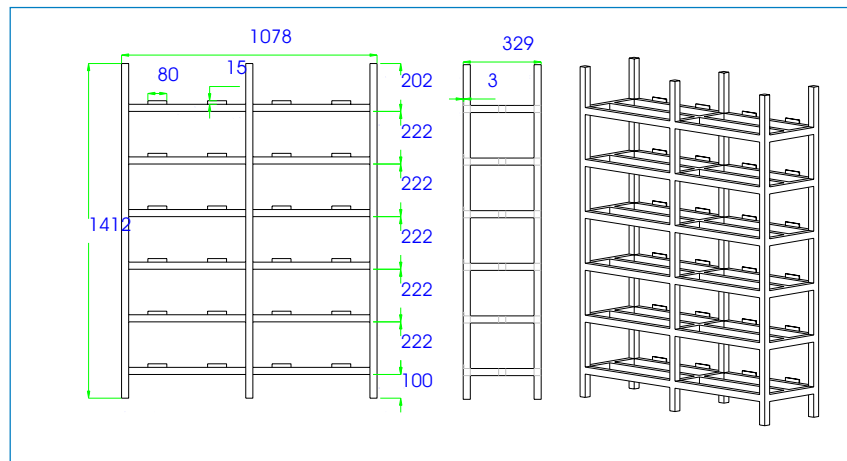



200307

VRLA Product Range

4, 6 & 12 Volt AGM 1.3 to 230AH

6 & 12 Volt Gel 7.5 to 230AH

12 Volt Front Access AGM

12 Volt Front Access Gel

2 Volt AGM & Gel 50 to 3850AH

EV Gel

EV AGM

Marine Gel

Solar