

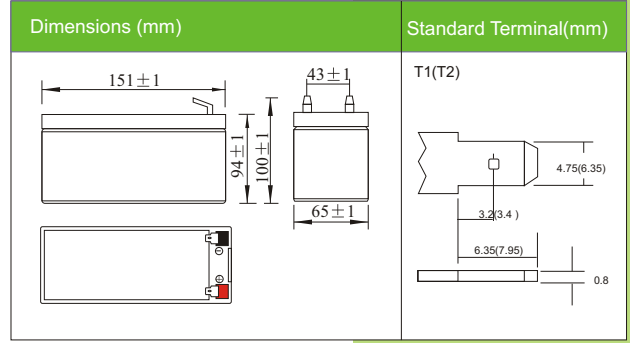

# DJW12-7.2(12V7.2AH)



PHYSICAL SPECIFICATION		
Nominal Voltage		12V
Nominal Capacity (20HR)		7.6AH
Dimension	Length	151 ± 1mm (5.95 inches)
	Width	65 ± 1mm (2.56 inches)
	Container Height	94 ± 1mm (3.70 inches)
	Total Height (with Terminal)	100 ± 1mm (3.94 inches)
Weight		Approx 2.60kg (5.73lbs)
Standard Terminal		T1 or T2(standard)

## Discharging Current & Discharge Duration Time

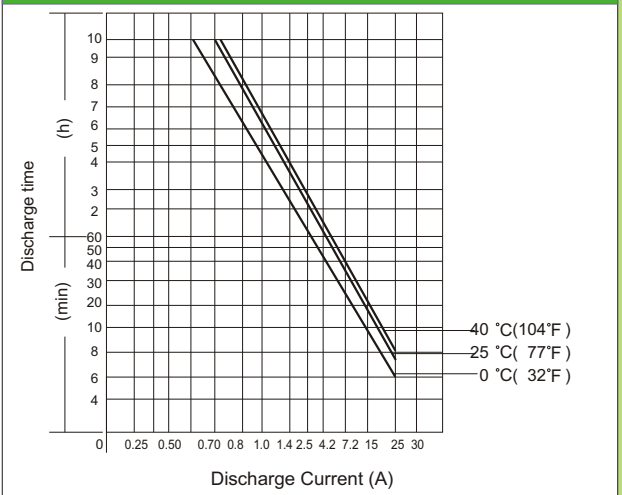

ELECTRICAL SPECIFICATION					
Rated Capacity	20 hour rate (380mA)	7.6AH	Constant-Voltage Charge	Cycle	Initial Charging Current less than 2.28A. Voltage 14.4V~15.0V at 25°C (77°F). Temp. Coefficient -30mV/°C
	10 hour rate (720mA)	7.2AH			
	5 hour rate (1.33 A)	6.65AH			
	1 hour rate (4.68A)	4.68AH			
Capacity affected by Temperature	15minute rate (14.4A)	3.6AH	Standby	No limit on Initial Charging Current Voltage 13.5V~13.8V at 25°C (77°F). Temp. Coefficient -20mV/°C	
	40°C (104°F)	103%			
	25°C (77°F)	100%			
Internal Resistance	0°C (32°F)	86%	Fully charged battery (25°C, 77°F) 18mΩ		

## Discharge Characteristics (25°C, 77°F)

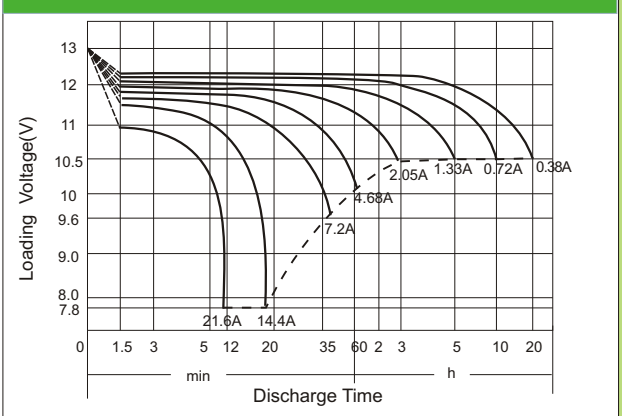

Constant Current (Amp) and Constant Power (Watt/Cell) Discharge Table											Discharge Time (Minute) to final voltage /cell			
Final voltage	Time	0.5	1	2	3	6	10	20	30	60	120	180	300	600
1.75V	A	48.3	44.3	38.3	30.6	23.3	18.5	9.1	7.8	4.6	2.6	2.1	1.33	0.72
25°C	W	76.5	65.7	56.7	45.3	34.9	29.7	16.5	10.9	8.4	5.1	4.0	2.7	1.44
1.70V	A	65.1	58.4	50.4	40.2	26.7	19.2	10.1	8.4	4.8	2.8	2.2	1.4	0.81
25°C	W	104.7	89.9	77.1	62.4	40.3	30.6	18.6	14.2	9.1	5.3	4.3	2.8	1.50
1.60V	A	84.6	74.5	62.4	49.1	31.8	20.4	11.8	9.0	4.9	2.9	2.3	1.5	0.86
25°C	W	122	105.4	89.2	70.1	45.1	34.6	21.1	14.8	9.7	5.5	4.5	2.9	1.60
1.75V	A	42.3	38.3	33.8	26.8	17.8	14.7	8.9	7.4	4.0	2.3	1.8	1.21	0.67
5°C	W	67.1	60.4	53.6	42.1	29.7	25.2	15.1	10.6	6.9	4.4	3.6	2.3	1.26
1.70V	A	58.4	53.6	45.9	36.4	23.8	18.0	9.5	7.7	4.3	2.4	1.9	1.26	0.71
5°C	W	89.9	79.2	68.9	55.5	37.7	28.0	17.3	12.7	7.8	4.7	3.7	2.4	1.37
1.60V	A	72.5	64.4	53.0	41.5	26.4	19.8	11.3	7.8	4.4	2.6	2.1	1.4	0.74
5°C	W	112.1	97.9	82.8	67.0	43.9	29.4	18.9	13.4	8.0	4.9	3.9	2.5	1.44